

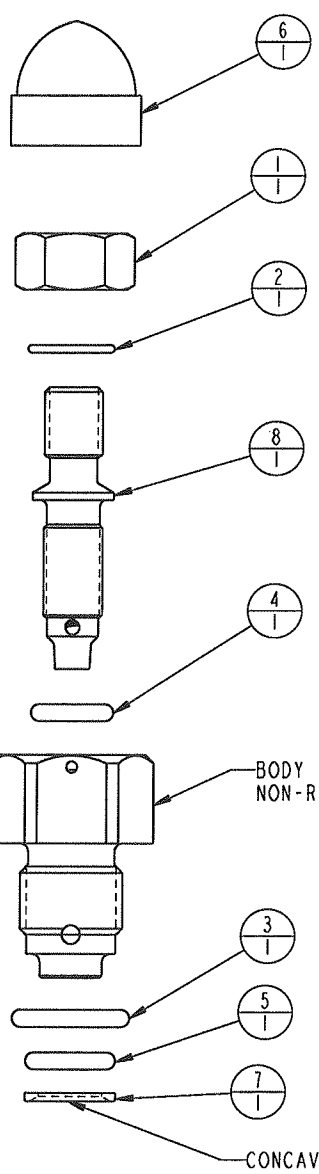

1			2	
MODEL NO.		MODEL NAME		
70203771		ASSY,FLOW CONTROL,SAE 4,580		
NO.	QTY	PART NO.	DESCRIPTION	SEAL KIT
1	1	21420020	NUT, HEX, 1/4-28, NYLON	NO
2	1	23002019	RETAINING RING, ROUND, INTL, 9mm	NO
3	1	39000070	O-RING, (-904), .351x.072,90 AU	YES
4	1	39000077	O-RING, (-009), .208x.070,90 AU	YES
5	1	39051004	O-RING, (-010), .239x.070,90 AU	YES
6	1	68050004	CAP, DOME, HEX, 1/4	NO
7	1	87000037	SPACER, FLOW CONTROL, SAE 4	NO
8	1	97020001	ASSY, NEEDLE & STEM, SAE4 / G1/4	NO
N/A	N/A	60701607	KIT, SEAL, FLOW CONTROL, SAE 4	NOTED



THIS IS A TWO PAGE PARTS LIST.
 THIS FIRST PAGE APPLIES TO
 MODEL NO. 70-2037-71 REVISION "D"
 AND LATER REVISIONS.
 THE SECOND PAGE APPLIES TO REVISION "C"
 AND EARLIER REVISIONS.



- NOTES:
 1. APPLY LUBRICANT TO ALL SEALS
 PRIOR TO INSTALLATION.
 2. DO NOT USE SILICONE TYPE LUBRICANTS.

PARTS LIST	 VEKTEK, INC. 1334 E. SIXTH AVE. P.O. BOX 625 EMPORIA, KS. 66801 U.S.A.
	ASSEMBLIES AFFECTED 70-2037-71
PARTS LIST, ASSY,FLOW CONTROL,SAE 4,.580 SIZE A PL7122	REV C SHEET 1 OF 1

C	2302	RELEASE	K. ROEMER	07/29/11
REV	IN ACCORDANCE WITH ECN	EFFECTIVE DATE	REVISED BY	DATE
DRW BY: GAV	DRAWING STATUS: Released			
DATE: 06/03/08	PRODUCTION APPROVED FOR RELEASED STATUS ONLY			

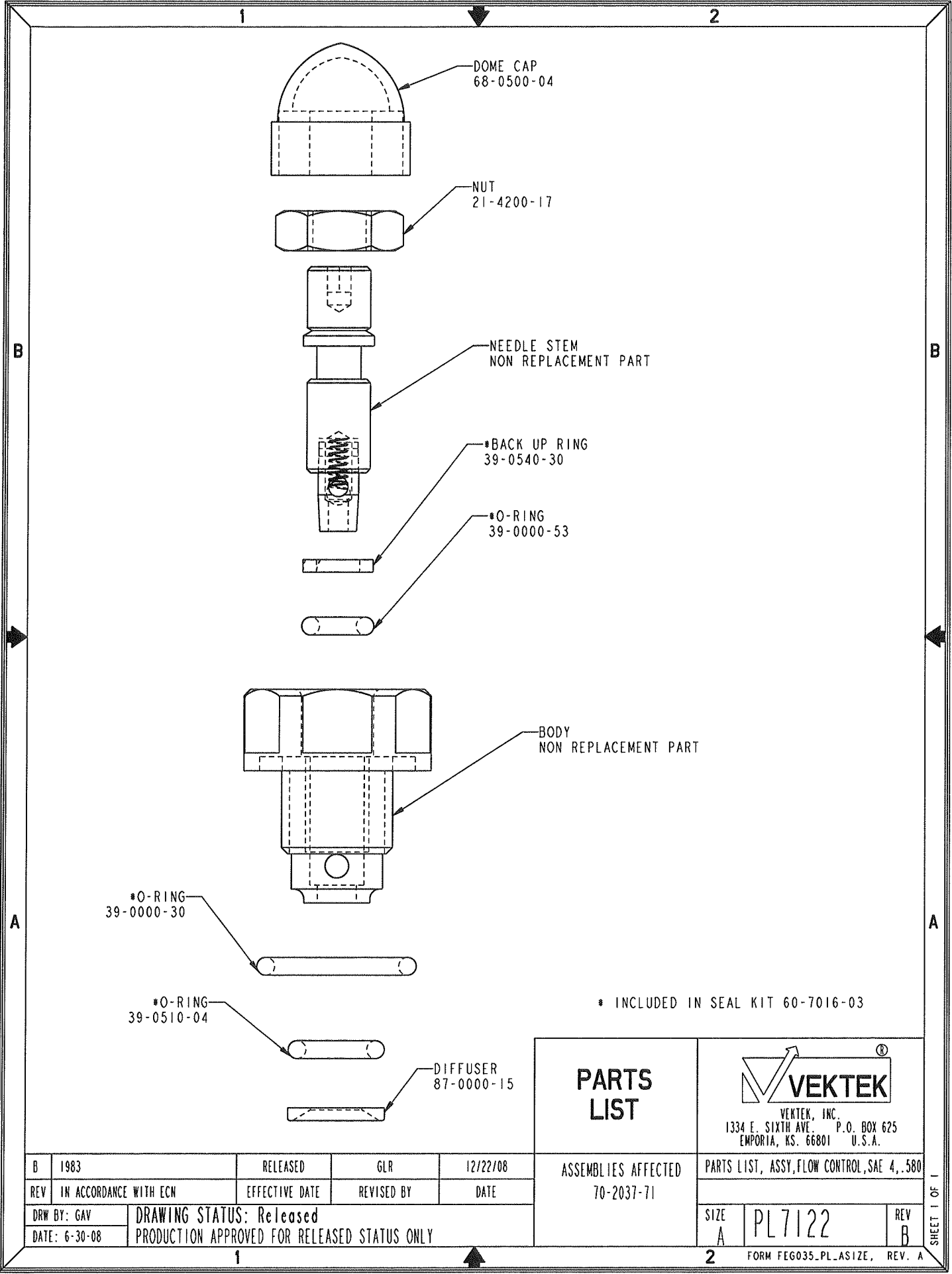

PARTS LIST	 VEKTEK VEKTEK, INC. 1334 E. SIXTH AVE. P.O. BOX 625 EMPORIA, KS. 66801 U.S.A.	
	ASSEMBLIES AFFECTED 70-2037-71	PARTS LIST, ASSY, FLOW CONTROL, SAE 4, .580
SIZE A	PL7122	REV B

B	1983	RELEASED	GLR	12/22/08
REV	IN ACCORDANCE WITH ECN	EFFECTIVE DATE	REVISED BY	DATE
DRW BY:	DRAWING STATUS: Released			
DATE: 6-30-08	PRODUCTION APPROVED FOR RELEASED STATUS ONLY			